



**INSTALLATION AND
PROGRAMMING MANUAL
FOR MODEL**

1810

PROGRAMMABLE LEVEL MONITOR



000-1005 Rev. D

TABLE OF CONTENTS

Section:	Page:
List of Figures.....	3
List of Tables.....	3
Introduction.....	4
Safety Instructions.....	4
1.0 Installation.....	5 - 9
2.0 Programming.....	10 – 18
2.1 Programming Examples.....	14 – 18
3.0 Options.....	19 – 26
3.1 Analog Output.....	19
3.2 High / Low Relay Limits.....	19
3.3 Serial RS-232.....	20
3.4 Parallel BCD	21
3.5 Multiplexed BCD.....	24
3.6 External Relays	26
4.0 Field Calibration and Test.....	27
5.0 Error Codes.....	29
6.0 Specifications.....	30
7.0 Repair.....	31

INTELLIGENT CONTROLS, INC.
PO Box 638
34 Spring Hill Road
Saco, Maine
04072 USA

Phone: 207-283-0156 FAX: 207-286-1459
Toll Free: Technical Service and Sales: 800-872-3455
Web Site: www.incon.com E-mail: sales@incon.com

This manual applies to all INCON model 1810 monitors.

Copyright 1989, 2004, Intelligent Controls, Inc. All rights reserved

LIST OF FIGURES

Figure:		Page:
1.1	Mechanical Dimensions.....	5
1.2	Field Wiring Diagram with Loop Powered Transmitter.....	6
1.3	Field Wiring Diagram with Self Powered Transmitter.....	6
1.5	Field Wiring Diagram for 4-20mA Analog Output.....	7
1.6	Field Wiring Diagram for Hi / Lo Relays.....	7
2.1	Simplified Programming Flowchart.....	10
3.1	Parallel BCD Timing.....	23
3.2	Multiple 1810's on Multiplexed BCD Buss.....	25
3.3	Multiplexed BCD Timing.....	25
3.4	External Relay Output Field Wiring.....	26
4.1	Analog Output Adjustment Pots.....	27

LIST OF TABLES

Table:		Page:
1.1	Terminal Functions.....	8
1.2	DIP Switch Functions.....	8
1.3	Baud Rate DIP Switch Functions.....	8
2.1	Programming Menu Structure.....	11-13
3.1	Analog Output Load Limits.....	19
3.2	Wiring: Digital Connector Pin-Out.....	21
3.3	Parallel Binary Examples.....	23
5.1	Error Codes	29

INTRODUCTION

The Model 1810 Programmable Level Monitor is a highly advanced solid-state instrument, which measures the 4 to 20 milliamp analog signal from a liquid level transducer. It is capable of converting this analog signal into an accurate level measurement. The 1810 can convert the level measurement into a volume measurement through the use of a tank table. It also allows simple mathematic functions to be performed on the measured value, and provides a user-definable visual panel indication, optional analog, digital, and alarm relay outputs suitable for a variety of monitoring and control applications.

The 1810 may be programmed to perform mathematical scaling and offsetting to the measured signal value. A special feature of the 1810 is its capability to convert a linear measured value into non-linear displayed units. This is particularly suited to converting the measured height of fluid in a tank into a volume readout. A conversion table containing up to 100 data point pairs may be programmed. The 1810 will take a measurement, refer to the conversion table, and display the converted value. Three separate mathematic scales can be programmed. Each can be displayed at the push of a button. Analog, digital, and relay outputs can each be driven from your choice of these three scales.

The 1810's powerful mathematic capability, combined with its non-linear conversion capability, and output options available makes it one of the most versatile and flexible instruments on the market.

SAFETY INSTRUCTIONS

General

The operation and programming of this device is not difficult if you read this manual and study the examples. However it is critical that you understand which programming values should be used for a particular installation. Failure to properly program the unit could cause either the display or electrical output to be incorrect. This, in turn, could cause damage to equipment or injury to personnel. In addition, be aware that the unit does not operate while it is being programmed. All outputs are disabled during the Programming Mode.

Power Source and Rear Terminal

All power connections are made to the rear terminals. The units are configured at the factory for either 120VAC or 240VAC. Verify that you have ordered the correct unit, as indicated on the label on the top of the case. When connecting power, make sure that power connections are made to the correct terminals, or else damage may occur. It is recommended, but not required that this unit be grounded properly. Always replace the rear terminal guard after wiring, to prevent accidental contact with hazardous voltage levels. We recommend that you use the spade lugs supplied for all wiring connections to the unit.

Fuse Replacement

Section 7.0 Repair, describes proper fuse replacement. For continued protection against the possibility of fire or damage to the unit, replace the fuse with a fuse of the specified voltage, current and type ratings. In order to reduce the risk of damage to the unit, do not perform any servicing other than that which is described in this manual.

1.0 INSTALLATION

- The Model 1810 is designed for use in any 120/240 VAC, 50/60 Hz system.
- The panel-mount case is designed to snap-fit into a **standard 1/8 DIN rectangular cut-out of 44mm (1.73 in.) by 92mm (3.62 in.)**
- Wiring is done to the rear of the case. #20 AWG (min.) shielded twisted pair wire is recommended for input and output wiring. Use appropriate spade lugs (provided) when connecting to the case terminals.
- Contact INCON Technical Service (1-800-872-3455) for application assistance.

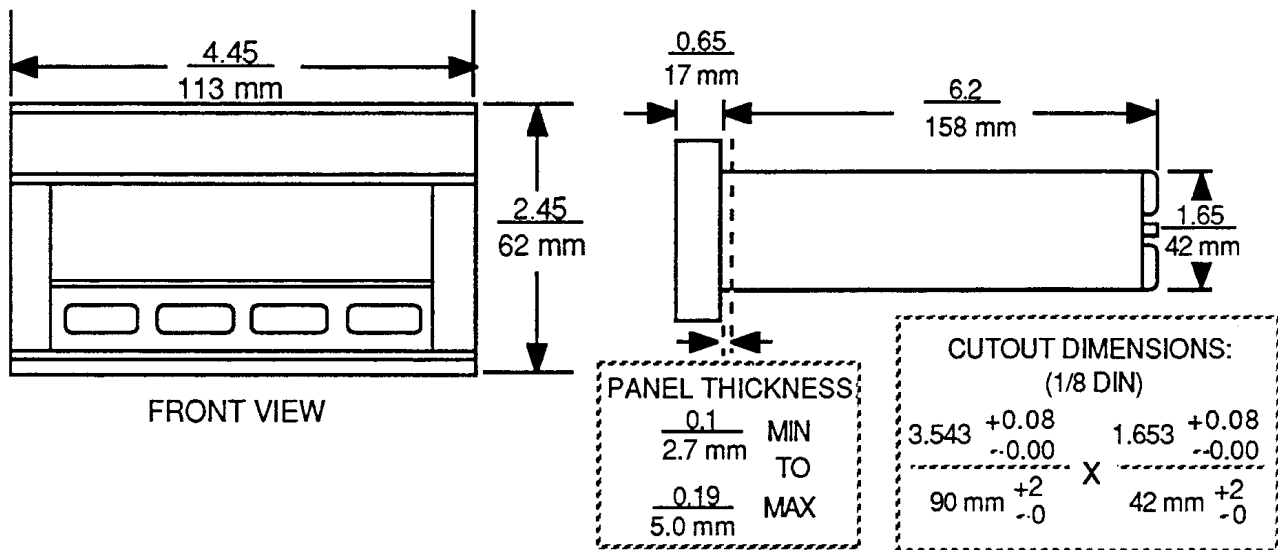

Figure 1.1 Mechanical Dimensions

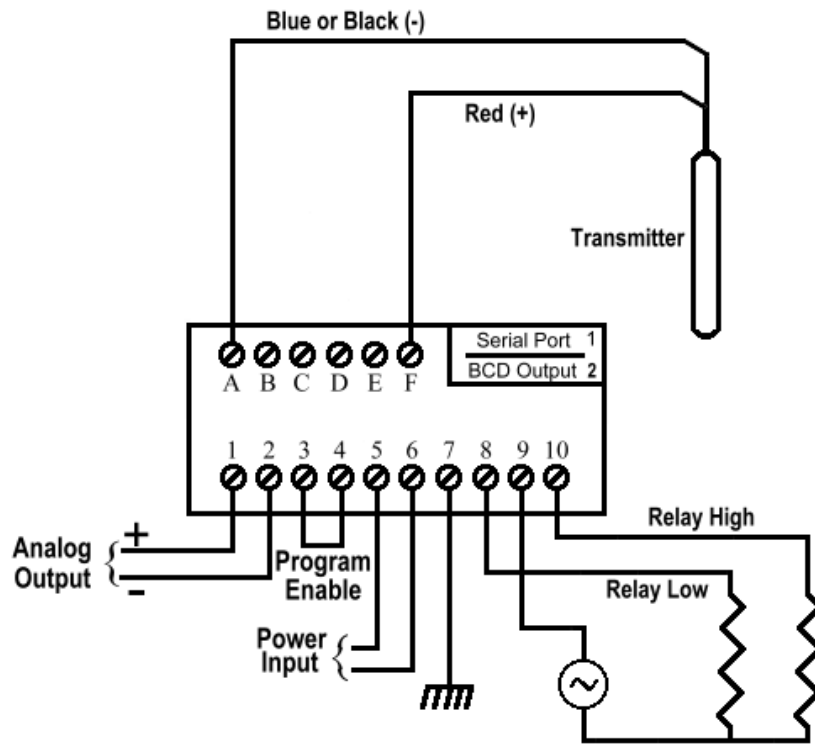

Figure 1.2 Field Wiring Diagram with Loop Powered Transmitter

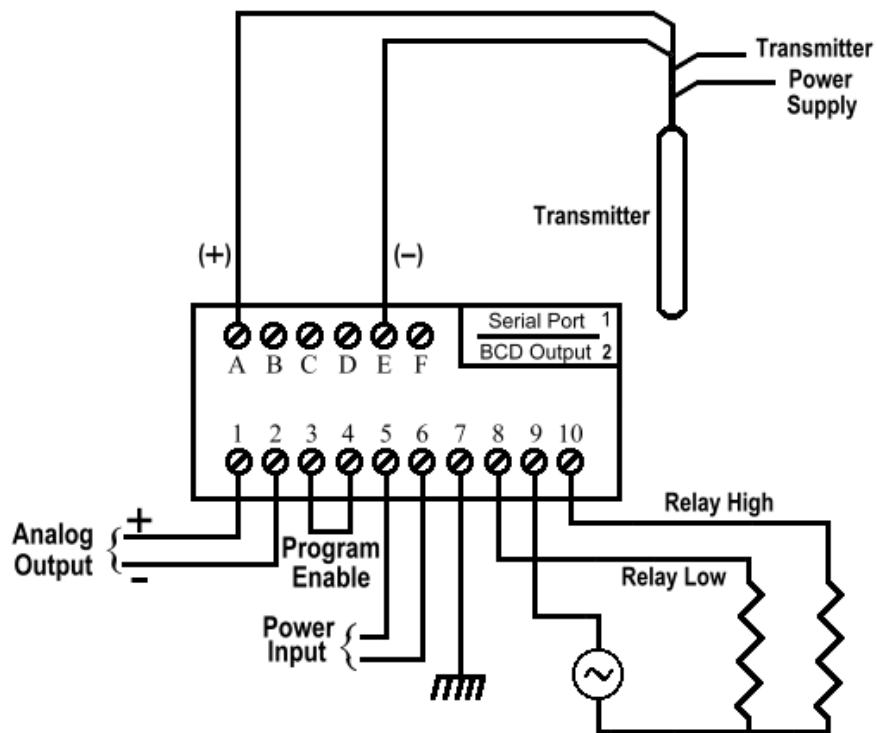

Figure 1.3 Field Wiring Diagram with Self Powered Transmitter

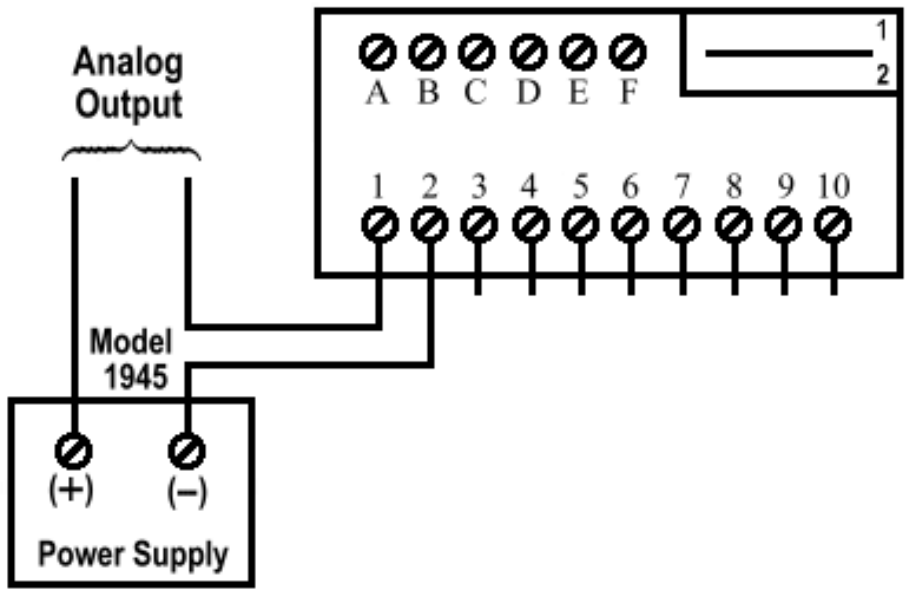

Figure 1.4 Field Wiring Diagram for 4-20mA Analog Output

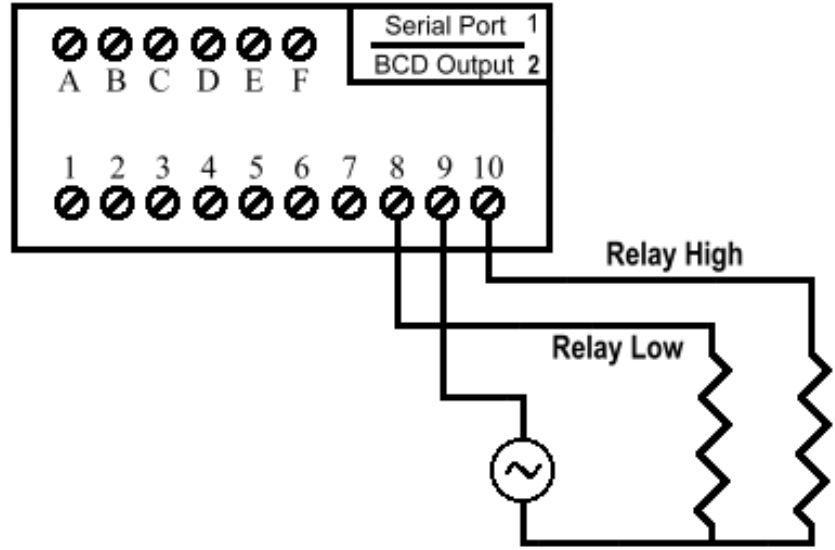

Figure 1.5 Field Wiring Diagram for Hi / Lo Relays

Table 1.1 Terminal Functions

Terminal	Function	Terminal	Function
A	Signal Input	1	Analog Output +
B	(Spare)	2	Analog Output –
C	(Spare)	3	Program Mode Enable
D	(Spare)	4	Enable Return
E	Signal Ground	5	Power Input
F	+24 VDC Transmitter Power	6	Power Input
		7	Chassis Ground
		8	Relay Low Contact N.O.
		9	Relay Common
		10	Relay High Contact N.O.

Table 1.2 DIP Switch Functions

Switch #	Function
1	RS-232 Communications Option Enable
2	Baud Rate Select (See Table 1.3)
3	Baud Rate Select (See Table 1.3)
4	High / Low Relay Limit Option Enable
5	Analog Output Option Enable
6	In-Factory Test & Calibration Menu Enable
7	BCD/BIN Option Enable
8	External Relay Option Enable

Table 1.3 Baud Rate DIP Switch Functions

Baud Rate	DIP Switch # 2	DIP Switch # 3
300	Off	Off
1200	On	Off
9600	Off	On
76800	On	On

Installation Notes:

- 1) A resistor may be wired remotely across the analog output terminals to convert analog output current to a voltage. Use Ohm's Law to calculate the proper resistance for the desired voltage based upon the 1810's rated output current.
- 2) Maximum analog output load resistance: 0-1mA = 10K ohms; +/-1mA = 10K ohms; 0-2mA = 5K ohms; 4-20mA = 500 ohms.
- 3) Models with 4-20 mA analog output options must have an EXTERNAL LOOP POWER SOURCE of 10.0 VDC minimum, 24.0 VDC maximum, in series with the current loop. The INCON Model 1945 Power Supply is recommended for these installations, (See Figure 1.4).
- 4) After installation and programming, install the rear terminal guard with screws provided.
- 5) For models with serial or BCD options, plug the cable onto the card edge with the red stripe towards the outside of the case.

Application Bulletins:

Analog outputs of 0-1mA, +/-1mA, and 0-2mA can be changed in the field to any one of the other two. The configuration jumpers are located on the bottom PCB.

For 0-1mA: jumper: J8, J12 & J13

For +/-1mA: jumper J10, J12 & J13

For 0-2mA: jumper J12 & J13

(See Application Bulletin #000-1151)

2.0 PROGRAMMING

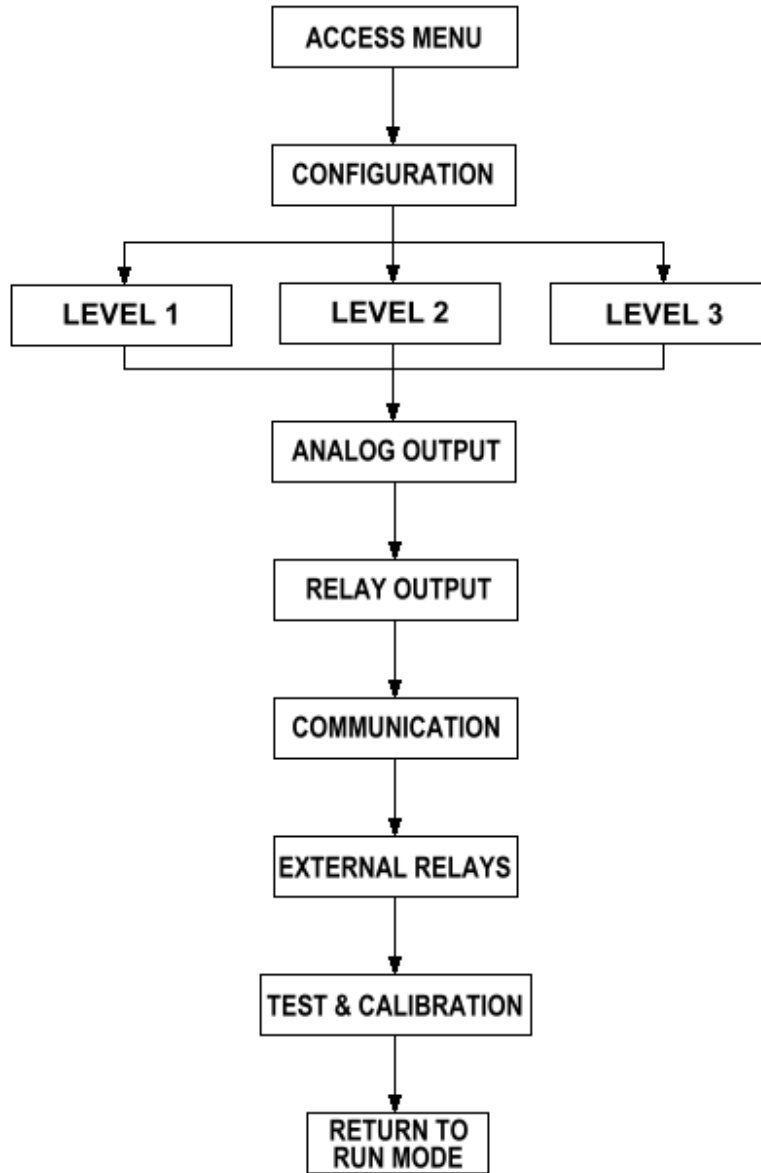

Figure 2.1 Simplified Programming Flowchart

To access the programming menu, momentarily jumper terminals 3 and 4. The display should read “run”. Press the UP or DOWN key to scroll through the main menu. To enter a sub-menu, press the ENTER key. Press the UP or DOWN key to scroll through the sub-menu items.

To change an item, press the ENTER key. The item’s present setting will now be displayed. You can change the setting by pressing the UP or DOWN key. (Numeric values are changed one digit at a time. Press the UP or DOWN key to change the digit, press the ENTER key to move to the next digit. When all digits are entered, the decimal point is positioned to the left or right using the UP or DOWN keys, and then the sign can be set to “POS” or “nEG.) To store the new setting, press the ENTER key. The display will return to the sub-menu item.

Table 2.1 Programming Menu Structure:

Main Menu:	Sub Menu:	Menu Item:	Function
run			Return to “Run” Mode by pressing the Enter key
COnF1			Configuration Menu
	UnItS	In-GA or CE-LI	Chose Height and Volume units of measure: Inches & Gallons or Centimeters & Liters
	Pr un	PSI, bAr, or PASCA	Chose Pressure Units of measure: PSI, Bar, or Pascals
	FS		Full Scale of sensor in pressure units (i.e: PSI)
		DDDDD	Full Scale Value
	LS		Low Scale of sensor in pressure units (i.e: PSI)
		DDDDD	Low Scale Value
	SPGrA	DDDDD	Specific Gravity Value
	FrE	60 or 50	Choose Line Frequency (Hz)
	InCAL		Input signal calibration utility (Factory use only!)
		LO CA	Calibrate to low scale input signal
		HI CA	Calibrate to high scale input signal
	HGCAL		Height calibration utility – Calibrates the 1810 to the actual sensor signal over a span of liquid level
		DDDDD	First Height Calibration value (mantissa, decimal point & sign POS / NEg)
		DDDDD	Second Height Calibration value (mantissa, decimal point & sign POS / NEg)
	StrAP		Strapping table sub-menu
		Add	Manually add both X and Y coordinates for one non-linear table entry
		dEL	Delete both coordinates for one non-linear table entry
		Edit	Change the X and/or Y coordinates for one non-linear table entry
		dISP	Display X or Y coordinates for each non-linear table entry, one at a time
LVL1			“Level 1” Menu
	rEF		Input signal reference
		Cur, Pre, HGt, or VOL	Choose between: Current, Pressure, Height, or Volume expression of the input signal
	SF		Scale Factor (multiplier)
		DDDDD	Value (mantissa & decimal point)
		POS or nEG	Sign
	dECP		Sets the number of decimal places displayed
		D	Chose 0 through 5 (5 = Automatic Floating Decimal Point)
	SEt		Offset added or subtracted from multiplied value
		DDDDD	Value (mantissa & decimal point)
		POS or nEG	Sign (“POS” = add or “NEG” = subtract)
	FIL		2 to the power of (this value) samples are averaged before being displayed
		D	Filter value (0 – 10)

Table 2.1 Programming Menu Structure: Continued

	tHrE		Filter Override Threshold (Display counts per second)
		D	Threshold Value (A display change greater than this value, per second, will cause the Filter to momentarily shut off)
LVL2			“Level 2” Menu, same as Level 1 Menu
LVL3			“Level 3” Menu, same as Level 1 Menu
rLYHI			High Relay Menu
	rEF	LVL1, LVL2, or LVL3	Relay limit driven from the displayed value from the chosen level
	Lt		High Relay Limit
		DDDDD	Value (mantissa, decimal point & sign POS / NEg)
	OPEr	nOLtC or LtC	Choose Operation of this Relay: Non-Latching or Latching
rLYLO			Low Relay Menu
	rEF	LVL1, LVL2, or LVL3	Relay limit driven from the displayed value from the chosen level
	Lt		Low Relay Limit
		DDDDD	Value (mantissa, decimal point & sign POS / NEg)
	OPEr	nOLtC or LtC	Choose Operation of this Relay: Non-Latching or Latching
AnA			Analog Output Menu
	rEF	LVL1, LVL2, or LVL3	Analog Output is driven from the displayed value from the chosen level
	HI		Analog output high reference limit
		DDDDD	Value (mantissa, decimal point & sign POS / NEg)
	LO		Analog output low reference limit
		DDDDD	Value (mantissa, decimal point & sign POS / NEg)
rS232			RS-232 Output Menu
	Func		Choose a function mode:
		OFF	Off
		dLOG	Data Logger Mode
		POL	Polled Mode
		SA	Sampled Mode
		StrO	Strobed Mode
	rEF	LVL1, LVL2, or LVL3	RS-232 output is driven from the displayed value from the chosen scale factor
	In		Interval for data logger in minutes:
		DD	Number of minutes (0-60) 0=once per second
	HI		High limit for data logger range
		DD	Value (mantissa, decimal point & sign POS / NEg)
	LO		Low limit for data logger range
		DD	Value (mantissa, decimal point & sign POS / NEg)
ErLY			External Relay Output Menu
	rEF	LVL1, LVL2, or LVL3	External Relay outputs driven from the displayed value from the chosen level
	Out 1		External Relay output #1 Sub-Menu
		SEL	Choose: Off, AC-HI (Active High), or AC-LO (Active Low)
		HI	External Relay output #1 high limit
		DDDDD	Value (mantissa, decimal point & sign POS / NEg)
		LO	External Relay output #1 low limit
		DDDDD	Value (mantissa, decimal point & sign POS / NEg)

Table 2.1 Programming Menu Structure: Continued

	Out 2		Same as Out 1 Sub-Menu
	.		(Note: there can be up to 8 external relays)
	Out 8		Same as Out 1 Sub-Menu
bCd			Binary Coded Decimal Output Menu
	Func		Chose BCD Output function mode:
		OFF	Off
		bCd	Multiplexed BCD mode
		bCdPH	Parallel BCD mode four highest display digits
		bCdPL	Parallel BCD mode four lowest display digits
		bIn 2	Binary 2's compliment mode
		bIn S	Binary sign plus magnitude mode
		bIn O	Straight binary mode with sign
	rEF		Digital output referenced to:
		LVL1, LVL2, or LVL3	Digital output driven from the displayed value from the chosen scale factor
OUCAL		LO, --, or Hi	Forces the analog output to high, mid, or low scale for calibration adjustments
tESt			Self-Test Menu
	LEd		LED test – lights up all display segments
	rS232		RS-232 echo test
		ECHO	The 1511 will echo ASCII characters received
	rLY		Hi/Lo Relay test
		LO or HI	Manually closes HI or LO relay contacts. Press Up or DOWN keys to alternate between relays

Programming for the Analog Output option is covered in Section 3.1.

Programming for the High/Low Relays option is covered in Section 3.2.

Programming for the Serial RS-232 Communication option is covered in Section 3.3.

Programming for the Parallel BCD option is covered in Section 3.4.

Programming for the Multiplexed BCD option is covered in Section 3.5.

Programming for the External Relays option is covered in Section 3.6.

Front Panel Buttons:

The 1810 has four buttons on the front panel for user interface.

These buttons have different functions in Programming and RUN Modes:

Program Mode button functions:

TEMP/Cancel Acts like a Cancel or ESC key, cancels data entry, backs you out of a menu

LVL1/UP Scrolls up through a menu, increments a numeric data

LVL2/DOWN Scrolls down through a menu, decrements a numeric data

ACKN/Enter Acts like an ENTER key, to enter into a menu or accept an entered data value

RUN Mode button functions:

TEMP/Cancel None

LVL1/UP Selects the “LVL1” Scale to be displayed

LVL2/DOWN Selects the “LVL2” Scale to be displayed

[LVL1/UP & LVL2/DOWN] When pressed together, selects the “LVL3” Scale to be displayed

ACKN/Enter Unlatches latched relay outputs

2.1 Programming Examples

This section describes, step-by step, how to program the 1810 for several common applications. The many other 1810 applications should be similar to one of the following examples. Refer to Table 2.1 for an overview of the Programming Menu.

2.1.1 Programming Example #1:

Reading a Signal from a Pressure / Depth Sensor

The 1810 can be used with any brand of pressure / depth sensor that has a 4-20mA output signal. Perform the following steps:

1. **Connect the sensor properly to the 1810** as shown in the appropriate wiring diagram on page 6.
2. **Cold Boot the monitor:**
 - 2.1 Press and hold the CANCEL key while applying power to the 1810. The display should read “FA-3” for a few seconds. This action deletes all previous programming and restores the monitor to factory default parameters.
3. **Enter the Program Mode:**
 - 3.1 Momentarily connect terminal 3 to terminal 4. The display should read, “run”
4. **Enter the Desired Height and Volume Units of Measure:**
 - 4.1 Press the UP key. The display should read “ConFI”. Press the ENTER key. The display should read “UnItS”. Press the ENTER key. The display should read “In-GA”. This indicates that the 1810 will use inches and gallons for height and volume readings. If centimeters and liters are the desired units of measure, press the UP key. The display will then read “CE-LI”. When the desired units of measure are chosen, press the ENTER key. The display should read “UnItS”.
5. **Enter the Desired Pressure Unit of Measure:**
 - 5.1 Press the UP key. The display should read “Pr un”. Press the ENTER key. The display should read “PSI”. This indicates that the 1810 will use Pounds per Square Inch for pressure readings. Select the desired unit of measure for pressure from this Sub-Menu by pressing the UP key. The choices are: **PSI, BAR, and PASCAL**. When the desired units of measure are chosen, press the ENTER key. The display should read “Pr un”.
6. **Enter the High Scale rating of the sensor:**
 - 6.1 Press the UP key. The display should read “FS”. Press the ENTER key. The display should read “00000” with the first “0” flashing. Enter the full scale rating of the sensor in the desired units of measure, position the decimal point, and enter the sign. (For example, if the 20.0mA output of a sensor corresponds to a reading of 5.0 PSI, enter “5.0000 POS”.) Press the ENTER key. The display should read “FS”.

7. **Enter the Low Scale rating of the sensor:**
 - 7.1 Press the UP key. The display should read “LS”. Press the ENTER key. The display should read “00000” with the first “0” flashing. Enter the low scale rating of the sensor in the desired units of measure, position the decimal point, and enter the sign. (For example, if the 4.0mA output of a sensor corresponds to a reading of 0.0 PSI, enter “0.0000 POS”.) Press the ENTER key. The display should read “LS”.

8. **Enter the Specific Gravity of the Liquid:**
 - 8.1 Press the UP key. The display should read “SPGrA”. Press the ENTER key. The display should read “10000” with the “1” flashing. Enter the specific gravity value of the liquid being measured. Press the ENTER key. The display should read “SPGrA”.

9. **Optional Height Calibration:**

(This process is the simplest way to insure accurate measurements, in the desired units of measure, with any offset, and compensate for any inaccuracies in the sensor.)

 - 9.1 Press the UP key until the display reads “HGCAL”. Press the ENTER key. The display should read “00000” with the first “0” flashing. Exert a known stimulus to the sensor at or near its lower limit. (For example, if the sensor is rated for 0 to 5 PSI, lift the sensor out of the liquid so the pressure stimulus would be zero PSI.)
 - 9.2 Enter the known value (This may be zero, or any positive or negative number that you want the 1810 to read at this pressure.) that corresponds to this known stimulus in the desired units of measure, position the decimal point, and enter the sign.
 - 9.3 Press the ENTER key. The display should read “00000” again with the first “0” flashing. Exert a known stimulus to the sensor near its upper limit. For example, if the sensor is rated for 0 to 5 PSI, you would submerge the sensor in the liquid to a known depth.)
 - 9.4 Enter the known value (This may be the present depth of the fluid, or any positive or negative number that you want the 1810 to read at this pressure.) that corresponds to this known stimulus in the desired units of measure, position the decimal point, and enter the sign. Press the ENTER key. The display should read “HGCAL”.

10. Press the CANCEL key once. The display should read “CO nFI”.

11. **Set up the Scale Factors:**
 - 11.1 Press the UP key. The display should read “LV L1”. Press the ENTER key. The display should read “rEF”. Press the ENTER key. The display should read “Cur”.
 - 11.2 Select the appropriate reference from this menu:
 - Cur** This reference will return a LINEAR CURRENT value scaled between 4.000 and 20.000, regardless of the programmed values for the sensor’s Low and Full Scale.
 - PrE** This reference will return a LINEAR PRESSURE value scaled between the Low Scale and Full Scale pressure values of the sensor
 - HGt** This reference will return a LINEAR HEIGHT value scaled based upon either: the Low Scale and Full Scale values of the sensor and the specific gravity of the fluid – OR– the slope of the Height Calibration data points.
 - UOL** This reference will return a NON-LINEAR VOLUME value based upon the conversion data table entered (See Programming Example #2).

- When the correct reference is selected, press the ENTER key. The display should read “**rEF**”.
- 11.3 Press the UP key. The display should read “**SF**”. Press the ENTER key. The display should read “**10000**” with the “1” flashing. (This is the Scale Factor, or Multiplication Factor. The reference value, measured by the sensor, as programmed in step 7.2 above, will be multiplied by this Scale Factor.) Enter the mantissa, locate the decimal point, and enter the sign for the desired Scale Factor. Press the ENTER key. The display should read “**SF**”.
 - 11.4 Press the UP key. The display should read **dEc P**. Press the ENTER key. The display should read “**1**”. (This variable sets the number of decimal places shown when the measurement is displayed. Keep in mind that there are only 5 digits on the display. More digits used for decimal places mean fewer digits available for integers. Plan for the highest integer value expected and set the decimal places accordingly. If “5” is selected, the display will automatically float the decimal point to render the highest display resolution possible.) Select the desired number of decimal places from this sub-menu and press the ENTER key. The display should read “**dEc P**”.
 - 11.5 Press the UP key. The display should read “**SET**”. Press the ENTER key. The display should read “**00000**” with the first “0” flashing. (This is the OFFSET value. This value will be ADDED to display value AFTER the reference value measured by the sensor is multiplied by the Scale Factor value.) Enter the mantissa, locate the decimal point, and enter the sign for the desired OFFSET. Press the ENTER key. The display should read “**SET**”.
 - 11.6 Press the UP key. The display should read “**FIL**”. Press the ENTER key. The display should read “**1**”. (This value governs how many display value samples are averaged before the display is updated. Two (2) to the power of this value samples will be averaged.) Change this value by pressing the UP or DOWN keys. Press the ENTER key. The display should read “**FIL**”.
 - 11.7 Press the CANCEL key once. The display should read “**LVL1**”.
 - 11.8 The 1810 has three programmable scales: LVL1, LVL2, and LVL3. The LVL2 and LVL3 scales can be programmed individually, using the same method as described above in steps 7.1 through 7.6. Press the UP key to select the “**LVL2**” or “**LVL3**” menus.
12. **Return to the RUN Mode:**
 - 12.1 Press the CANCEL key until the display reads “**run**”. Press the ENTER key. The 1810 is now in the RUN Mode. The display should read a number that represents the measured Reference value, multiplied by the Scale Factor and offset by the SET value.

In the RUN Mode, the three scales can be displayed separately by pressing the “**LVL1**” or “**LVL2**” key, or both keys for scale “**LVL3**”. Selecting a different scale changes the display only, all outputs (analog, relays, communication, etc...) are separately referenced to one of these scales (See section 3.0 Options). The outputs are not affected by changing the display scale.

2.1.3 Programming Example #2:

Reading the Volume in a Tank

The 1810's 100-point Strapping Table can be used to convert a linear height measurement into a volume reading. Up to 100 conversion data points can be entered into the 1810's Strapping Table. It is not necessary to enter all 100 data points, although the more data points entered, the more precisely the conversion curve will be defined. The 1810 will automatically interpolate the conversion between data points. Perform the following steps to program the 1810 for reading the volume in a tank:

1. **Perform Steps 1. through 10. under Programming Example #1 (2.1.1) above.**
2. **Enter the Strapping Table data:**
 - 2.1 The display should read "**COntFI**". Press the ENTER key. The display should read "**UnItS**". Press the DOWN key. The display should read "**StrAP**". Press the ENTER key. The display should read "**Add**".
 - 2.2 Press the ENTER key. The display should read "**00000**" with the first "0" flashing. Enter the first HEIGHT value from the tank manufacturer's height-to-volume conversion table (Notice that the round LED above the UP key is lit. This LED indicates that the data about to be entered is the Height Value of a data point pair.), position the decimal point, and enter the sign. Press the ENTER key. The display should read "**00000**" with the first "0" flashing.
 - 2.3 Enter the first VOLUME value from the tank manufacturer's height-to-volume conversion table (Notice that the round LED above the DOWN key is lit. This LED indicates that the data about to be entered is the Volume Value of a data point pair.), position the decimal point, and enter the sign. Press the ENTER key. The 1810 will enter both the Height value and the Volume Value into the Strapping Table as a data point pair. The display should now read "**Add**".
 - 2.4 Repeat steps 2.2 and 2.3 until the full range of the tank's height-to-volume conversion table has been entered. (Note: Not every conversion data point pair needs to be entered for a satisfactory volume conversion to be done. Obviously, the more points entered, the more precisely the volume conversion will be done.)
3. **Set up the Scale Factors:**
 - 3.1 Press the UP key. The display should read "**LVL1**". Press the ENTER key. The display should read "**rEF**". Press the ENTER key. The display should read "**CUr**".
 - 3.2 Select "**UOL**" from this menu. This reference will return a NON-LINEAR VOLUME value based upon the Strapping Table data entered. Press the ENTER key. The display should read "**rEF**".
 - 3.3 Press the UP key until the display reads "**dEc P**". Press the ENTER key. The display should read "**1**". (This variable sets the number of decimal places shown when the measurement is displayed. Keep in mind that there are only 5 digits on the display. More digits used for decimal places mean fewer digits available for integers. Plan for the highest integer value expected and set the decimal places accordingly.) Change this value to the desired number of decimal places and press the ENTER key. The display should read "**dEc P**".

- 3.4 Press the UP key until the display reads “**FIL**”. Press the ENTER key. The display should read “**1**”. (This value governs how many display value samples are averaged before the display is updated. Two (2) to the power of this value samples will be averaged.) Change this value by pressing the UP or DOWN keys. Press the ENTER key. The display should read “**FIL**”.
- 3.5 Press the CANCEL key once. The display should read “**LVL1**”.
4. **Return to the RUN Mode:**
 - 4.1 Press the CANCEL key until the display reads “**run**”. Press the ENTER key. The 1810 is now in the RUN Mode. The display should read a number that represents the measured fluid height, converted to volume.
 - 4.2 If an “**FA 6**” error is displayed, check the height measurement from the sensor, using one of the other scales (LVL1, LVL2, or LVL3). This error indicates that the present height measurement is above the highest height value or below the lowest height value in the Strapping Table. Use the “**SEt**” item in the appropriate LVL menu to correctly offset the height measurement, or re-do the “**HGCAL**” procedure (Steps 9. to 9.4 on page 15) to correct the height calibration.
 - 4.3 If an “**FA 7**” error is displayed, it indicates that there was an error made while entering the data into the Strapping Table. The volume values must correspond to the height values in ASCENDING ORDER. As the height values increase, the volume values must also increase from one data point pair to the next. To correct this error: use the “**Edit**” function in the StrAP menu to find and change the data that was entered incorrectly.

3.0 OPTIONS

The Model 1810 may be configured with one or more options. This section describes general use of each option, including wiring and programming for each option.

3.1 Analog Output Option “-0”, “-1”, “-2”, “-4”

The analog output on the 1810 may be used to feed measurement information to a remote monitoring or control system. The analog output is directly proportional to the display value of the chosen scale factor (see “rEF” under the AnA menu in the table on page 12), regardless of which scale value is being displayed at the time.

Wiring Note:

The 4-20mA analog output option must be wired with an external power supply of **12.0 to 24.0 volts DC** in series with the analog output current loop. (See Figure 1.5) The **INCON Model 1945** is available for this purpose. All other analog output options are self-powered. Refer to Table 3.1 below for analog output load limits.

Table 3.1 Analog Output Load Limits

Analog Output:	Load Minimum	Load Maximum
0 to 1 mA	Zero Ohms	10K Ohms
+/- 1 mA	Zero Ohms	10K Ohms
0 to 2 mA	Zero Ohms	5K Ohms
4-20 mA	Zero Ohms	500 Ohms

3.1.1 Programming for the Analog Output Option “-0, -1, -2, -4”

The analog output must be referenced to one of the three scales, LVL1, LVL2 or LVL3. This is defined within the **AnA** menu, in the item called “**rEF**”. The analog output will span between an upper and lower display limit. The output will be at its minimum output when the referenced scale’s display value is at the lower limit. The output will be at its maximum output when the referenced scale’s display value is at the upper limit. The analog output is unaffected when the display value of another scale is being displayed. To set the upper and lower display limits for the analog output, program the desired values in the items called “**HI**” and “**LO**”. The analog output will span automatically between these two limits.

3.2 High / Low Relay Limits Option “-R”

The High / Low Relays may be used as feedback in a control system or as an alarm when the measurement has exceeded desired limits. The high and low relays are normally open, dry contacts that do not latch when they are turned on. When the measured value falls **below the low relay limit, the low relay turns on**. When the measured value rises above the low relay limit, the low relay will turn off. When the measured value rises **above the high relay limit the high relay turns on**. When the measured value falls below the high relay limit, the high relay turns off.

3.2.1 Programming the Relay Limits

The High and Low Relay outputs must separately be referenced to any one of the three scales, LVL1, LVL2 or LVL3. This is defined within the **rLYHI** and **rLYLO** menus, in the item called “**rEF**” (see page 12). To set the high and low relay limits, program the desired values in the item called “**Lt**” within the **rLYHI** and **rLYLO** menus.

3.3 Serial RS-232

The Serial RS-232 option on the Model 1810 can be used to retrieve measurement data from the instrument. There are five operating modes for the serial RS-232 port. These are selected from the “**Func**” sub-menu in the **rS232** menu. The serial RS-232 data must be referenced to one of the three scales, LVL1, LVL2 or LVL3. This is defined within the **rS232** menu, in the item called “**rEF**”.

Serial Disabled This mode stops all serial communication. To enable this mode, select “**OFF**” from the **Func** menu.

Data Logger Mode This mode causes the 1810 to transmit the present position value on the display (including sign) once each time interval. To enable this mode, select “**dLOG**” from the **Func** sub-menu. The time interval is defined within the **rS232** menu in the item called “**In**”. The unit of measure for this interval is Minutes. An interval of zero minutes will cause the 1810 to transmit the position data once per second.

Polled Mode When this mode is selected, the 1810 can be interrogated at any time via the RS-232 port for the current position. This is done by first instructing the 1810 to latch the current position by transmitting an asterisk (*) to the unit. The position is then extracted, one character at a time, by transmitting the digits 0 through 6. Zero causes the sign character to be transmitted, 1 through 6 causes each position digit to be sent. The decimal point, wherever it may be positioned, is considered to be a digit. To enable this mode, select “**POL**” from the **Func** sub-menu.

Sampled Mode When this mode is selected, the 1810 can be interrogated at any time via the RS-232 port for current position by transmitting a question mark (?) to the 1810. When the 1810 receives a question mark, it responds by latching the current position and transmitting the value on the display in ASCII form. To enable this mode, select “**SA**” from the **Func** sub-menu.

Strobed Mode When this mode is selected, the 1810 can be interrogated at any time via the RS-232 port for current position by electrically pulling the /STROBE line low (See Table 3.8 DB25 connector pin #9). When the 1810 detects the /STROBE line is low, it responds by latching the current position and transmitting the value on the display in ASCII form. To enable this mode, select “**StrO**” from the **Func** sub-menu.

The communication port settings: word length, parity, and stop bits are not programmable. They are: **8** bit word length, **NO** parity, and **1** stop bit. Only the baud rate can be changed via DIP switches #2 & 3 (see Table 1.3).

Table 3.2 Wiring: Digital Connector Pin-Out

DB-25 Pin#	1810 Pin#	Multiplexed BCD Function (I/O)	Parallel BCD Function I/O	Parallel BIN Function I/O	RS-232 Function
1	1	Chassis Ground	Chassis Ground	Chassis Gnd.	Chassis Gnd.
14	2		Digit 0, Bit 0 (O)	Data Bit 0 (O)	
2	3		Digit 0, Bit 1 (O)	Data Bit 1 (O)	Transmit (O)
15	4		Digit 0, Bit 2 (O)	Data Bit 2 (O)	
3	5		Digit 0, Bit 3 (O)	Data Bit 3 (O)	Receive (I)
16	6	Sign (O)	Digit 1, Bit 0 (O)	Data Bit 4 (O)	
4	7		Digit 1, Bit 1 (O)	Data Bit 5 (O)	RTS (O)
17	8	Data Bit 3 (O)	Digit 1, Bit 2 (O)	Data Bit 6 (O)	
5	9		Digit 1, Bit 3 (O)	Data Bit 7 (O)	CTS (I)
18	10	Data Bit 2 (O)	Digit 2, Bit 0 (O)	Data Bit 8 (O)	
6	11	/Digit 3 Select (I)	Digit 2, Bit 1 (O)	Data Bit 9 (O)	
19	12	Data Bit 1 (O)	Digit 2, Bit 2 (O)	Data Bit 10 (O)	
7	13	Signal Ground	Signal Ground	Signal Ground	Signal Gnd.
20	14	Data Bit 0 (O)	Digit 2, Bit 3 (O)	Data Bit 11 (O)	
8	15	/Digit 3 Select (I)	Digit 3, Bit 0 (O)	Data Bit 12 (O)	
21	16	Data Valid (O)	Digit 3, Bit 1 (O)	Data Bit 13 (O)	
9	17	/Select & Hold (I)	Data Valid (O)	Data Valid (O)	/ Strobe
22	18	/Digit 4 Select (I)	Digit 3, Bit 2 (O)	Data Bit 14 (O)	
10	19	/Digit 1 Select (I)	Digit 3, Bit 3 (O)	Data Bit 15 (O)	
23	20	/Digit 2 Select (I)	Sign (O)	/Sign Data Bit 16 (O)	

3.4 Parallel BCD/BIN Option “-PB”

The Parallel BCD/BIN output on the Model 1810 can be used to communicate position values to a parallel digital input device. All parallel lines are TTL and CMOS compatible. Outputs are open collector type with 10K-ohm internal pull-up resistors to +5VDC, capable of pulling a 1K-ohm resistor to a TTL low state. All outputs are high-true and referenced to signal ground. The maximum switching capability is 5VDC, 100mA.

3.4.1 Programming the Parallel BCD/BIN Output

The Parallel BCD output can be referenced to any one of the three scale factors, LVL1, LVL2 or LVL3. This is defined within the **bCd** menu, in the item called “**rEF**”.

The 1810 can be programmed for two modes of Parallel Binary Coded Decimal and three modes of Parallel Binary. Refer to Figure 3.1 for Parallel BCD timing. Use the “**Func**” sub-menu in the **bCd** menu to select a parallel BCD/BIN mode:

BCD Disabled This mode stops all BCD communication. To enable this mode, select “**OFF**” from the **Func** sub-menu.

Multiplexed BCD Mode: (See Section 3.5 below)

Parallel BCD High Mode: In this mode the 1810 will provide a 4 digit BCD (17 bits - 4 bits per digit, plus a sign bit) representation of the displayed value. This value will correspond exactly to the four highest digits on the display. The right-most digit will not be represented in BCD. No indication of decimal point will be provided. To enable this mode, select “**bCdPH**” from the **Func** sub-menu.

Parallel BCD Low Mode: In this mode the 1810 will provide a 4 digit BCD (17 bits - 4 bits per digit, plus a sign bit) representation of the displayed value. This value will correspond exactly to the four lowest digits on the display. The left-most digit will not be represented in BCD. No indication of decimal point will be provided. To enable this mode, select “**bCdPL**” from the **Func** sub-menu.

Parallel Binary 2’s Complement Mode: In this mode the 1810 will provide a 17 bit (16 bit magnitude plus sign bit) **binary** 2’s complement representation of the complete displayed value. (See Table 3.9 for an example) No indication of decimal point will be provided. To enable this mode, select “**bIn 2**” from the **Func** sub-menu.

Parallel Binary Sign Plus Magnitude Mode: In this mode the 1810 will provide a 17 bit (16 bit magnitude plus sign bit) **binary** sign plus magnitude representation of the complete displayed value. (See Table 3.9 for an example) No indication of decimal point will be provided. To enable this mode, select “**bIn S**” from the **Func** sub-menu.

Parallel Offset Binary Mode: In this mode the 1810 will provide a 17 bit (16 bit magnitude plus sign bit) offset **binary** representation of the complete displayed value. (See Table 3.6 for an example) No indication of decimal point will be provided. To enable this mode, select “**bIn 0**” from the **Func** sub-menu.

The 1810 will update the Parallel BCD/BIN output at least every 100 milliseconds but not more often than every 60 milliseconds. The DATA VALID line will be high when data is stable and may be safely read. The DATA VALID line will go low to indicate that the data is being updated. The DATA VALID line will return high after data has been updated and is stable.

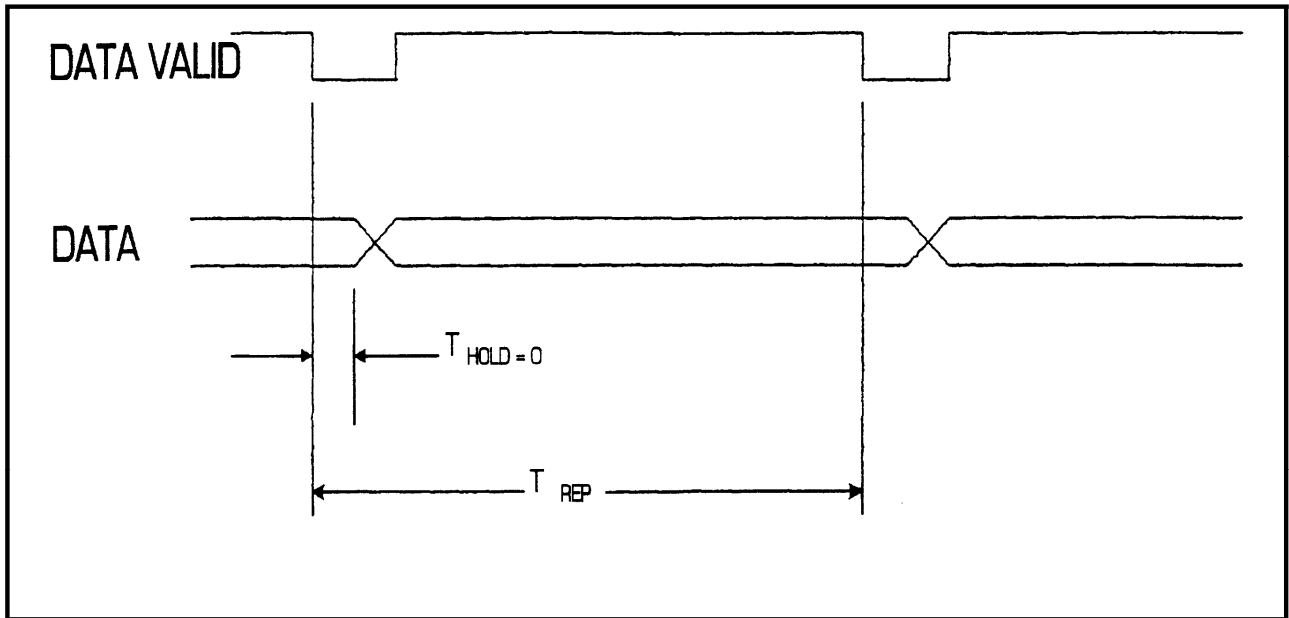

Figure 3.1 Parallel BCD Timing

Table 3.3 Parallel Binary Examples

Example of Binary 2's Complement	
	17 Binary Bits:
+2	00000000000000010
+1	00000000000000001
0	00000000000000000
-1	11111111111111111
-2	11111111111111110
Example of Binary Magnitude Plus Sign	
+2	00000000000000010
+1	00000000000000001
0	00000000000000000
-1	10000000000000001
-2	10000000000000010
Example of Offset Binary	
+65535	11111111111111111
+1	10000000000000001
0	10000000000000000
-1	01111111111111111
-65535	00000000000000000

3.5 Multiplexed BCD Option “-B”

The Multiplexed BCD output on the Model 1810 can be used to transmit position values - one digit at a time - to a remote device.

All inputs and outputs are TTL and CMOS compatible. Outputs are open collector type with 10K-ohm internal pull-up resistors to +5VDC, capable of pulling a 1K-ohm resistor to a TTL low state. All outputs are high-true and referenced to signal ground. All inputs have 10K-ohm internal pull-up resistors to +5VDC.

Since the BCD data is multiplexed, only one display digit at a time is available on the five BCD output lines (**Data Bit 1, Data Bit 2, Data Bit 3, Data Bit 4, and SIGN**). The BCD value sent will correspond exactly to the referenced (LVL1, LVL2, LVL3) display value. There will be no indication of decimal position sent. Refer to Table 3.2 for pin-out of the digital connector used for the BCD interface.

The timing between the /SELECT&HOLD, /DIGIT SELECT, and DATA VALID lines is somewhat critical as shown in the timing diagram (See Figure 3.3). In situations with multiple 1810's on the same MPX BCD buss, the /SELECT&HOLD line has a dual function. It is used to select which unit is active, and it holds the data for a particular reading (See Figure 3.2).

To select a digit to be transmitted, the /SELECT&HOLD line is first brought LOW. The DATA VALID line will go LOW after approximately 200 nS (T_{sdi}) indicating that the DATA is INVALID while the 1810 is updating its measurement. The DATA VALID line will remain LOW for a maximum of 35 mS (T_{acc}). When the DATA VALID line goes HIGH, any one of the /DIGIT *n* SELECT lines can be brought LOW to select a particular digit to be transmitted on the BCD output. Note that you should design your system such that it scans the DATA VALID line and then brings the /DIGIT *n* SELECT lines low as soon as the DATA VALID line goes HIGH. Note that whenever the /SELECT&HOLD or any of the /DIGIT *n* SELECT lines change state, the DATA VALID line will go LOW after approximately 200 nS (T_{sdi}) for a maximum of 35 mS (T_{acc}). Data access time can be saved if the /SELECT&HOLD line and /DIGIT *n* SELECT lines change state at exactly the same time.

After reading digits you must bring the /SELECT&HOLD line high for a minimum of 35 mS. The DATA VALID line will go LOW (after T_{sdi}) for a maximum of 35 mS. To minimize T_{uH}, the system should scan the DATA VALID line until it goes HIGH. Then immediately bring the /SELECT&HOLD line LOW.

3.5.1 Programming the Multiplexed BCD Output

To enable this mode, select “**bCd**” from the **Func** menu. The Multiplexed BCD output can be referenced to any one of the three scales, LVL1, LVL2 or LVL3. This is assigned by selecting **LVL1, LVL2** or **LVL3** under the “**rEF**” item in the **bCd** menu

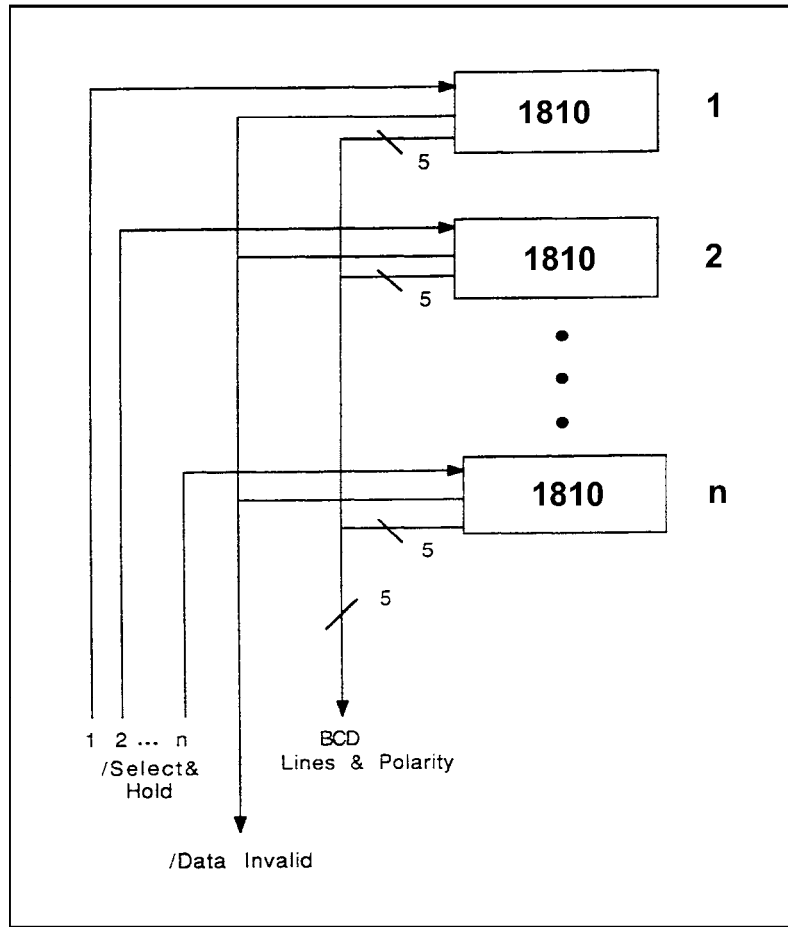

Figure 3.2 Multiple 1810's on Multiplexed BCD Bus

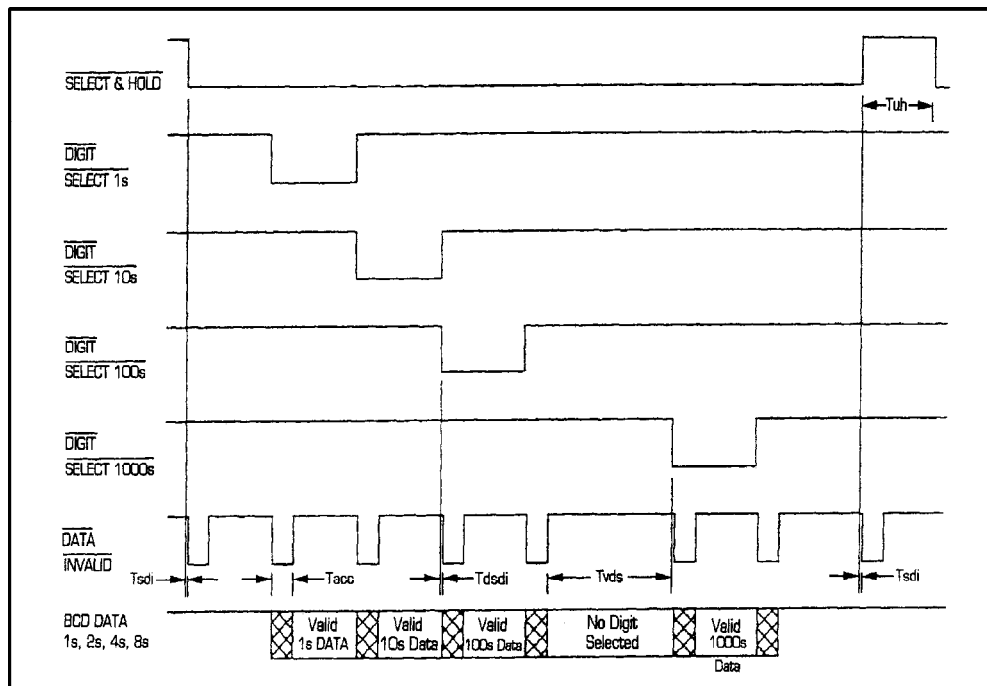

Figure 3.3 Multiplexed BCD Timing

3.6 External Relay Option “-E”

The External Relay outputs on the 1810 can be used to drive a solid state relay card, such as the OPTO-22 model PB-8, with up to 8 relays installed. They can be used for control, feedback, and alarms.

3.6.1 Programming the External Relay Outputs

The External Relay outputs are highly programmable, meaning that they can be programmed as “Active-High” or “Active-Low”, and can be activated between two programmable limits. The “ErLY” menu is the main menu for programming the External Relays (see Table 2.1 on page 12).

The External Relay outputs, as a group, must be referenced to any one of the three scales: LVL1, LVL2 or LVL3. This is defined by selecting **LVL1**, **LVL2** or **LVL3** under the “rEF” item in the **ErLY** menu

Each relay output (1 through 8) is separately programmable. This is done through the **Out 1** through **Out 8** Sub-Menus. Each relay can be selected Active-High or Active-Low, or OFF. This is defined in the sub-menu item called “SEL” by selecting “OFF”, “AC-HI”, or “AC-LO”. When the relay is selected Active-High, the relay output will be OFF until it is active. The relay will turn ON when it is active. When the relay is selected Active-Low it operates just the opposite, the relay output will be ON until it is active. The relay will turn OFF when it is active.

Each relay output can be set to be active between a Low and High Limit. The Low and High Limits are defined in the sub-menu items called “LO” and “HI”.

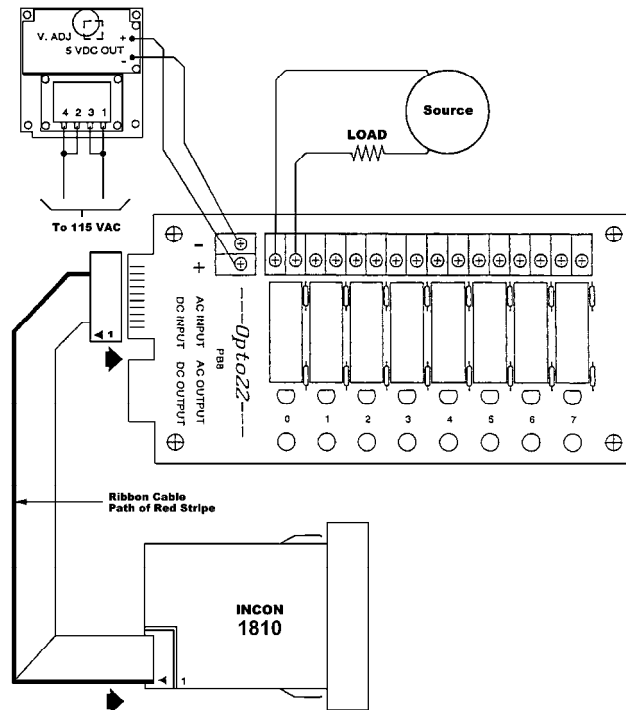

Figure 3.4 External Relay Output Field Wiring

4.0 Field Calibration and Test

Calibration: The Model 1810 should not require field calibration. However, there are provisions in the menu to facilitate Signal Input Calibration and Analog Output Calibration. Signal Input Calibration cannot be performed in the field; it is strictly an in-factory function. The analog output may be adjusted in the field. A calibrated multi-meter should be used to measure the output signal during calibration.

To enable analog calibration, select the **OUCAL** menu command, the display should read **“LO”**, **“- -”**, or **“HI”**. The analog output may be forced to LOW, MID, and HIGH output signal states.

Select the **“LO”** command to force the analog output to LOW scale output. The analog output low scale may now be adjusted by turning the **“ZERO”** pot, accessible through the slot in the left side of the case (see Figure 4.1), until the output signal is reading properly on the multi-meter.

Select the **“HI”** command to force the analog output to HIGH scale output. The analog output high scale may now be adjusted by turning the **“SPAN”** pot (see Figure 4.1) until the output signal is reading properly on the multi-meter. Repeat analog LOW and HIGH calibration steps several times to assure proper output signal calibration of both. Some interaction may occur between the ZERO and SPAN adjustments.

Select the **“- -”** command to force the analog output to MID scale output. The analog output should read a mid-scale signal on the multi-meter. There is no adjustment for this mid-scale output.

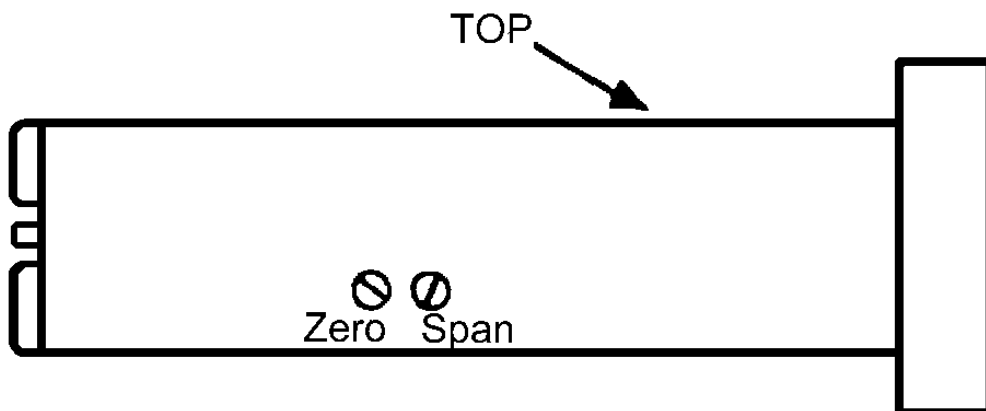

Figure 4.1 Analog Output Adjustment Pots

Self-Diagnostic Tests: The Model 1810 regularly performs a number of self-check diagnostic tests and generates error codes in the form “FA *n*” if it detects an internal fault. The “*n*” number indicates the type of failure detected. See Section 5.0 for a full list of error codes and their explanation.

Power Fail: The 1810 is designed to shut its microprocessor off when it detects the line voltage falling below a fixed threshold, typically 85 to 105 / 170 to 210 VAC. This feature enables the microprocessor to properly store its data before the power is lost completely. The 1810 will automatically re-start when the line voltage rises above the Power Fail Threshold voltage.

The software revision number can be displayed by pressing the “ENTER” key while turning on the power to the 1810.

The 1810 has the capability to delete all user-programmed values and restore all factory default program values. This “cold boot” is accomplished by pressing the “CANCEL” key while turning on the power to the 1810. There is no way to undo the effects of a cold boot.

The LED display can be tested. Enter the **TEST** menu and select **LEd** to turn on all display LED’s. Press the ENTER key to stop the test.

The RS-232 port can be tested. Enter the **TEST** menu and select **rS232** to enter the RS-232 Echo Test mode. With a computer terminal connected to the serial port, type in some characters. The 1810 should receive these characters and re-transmit them back to the terminal. The characters typed should appear on the terminal display. Press the ENTER key to stop the test.

The High / Low relays can be tested. Enter the **TEST** menu and select **rLY** to turn on one of the relays. The UP and DOWN keys will cause the 1810 to toggle between activating the High and Low relay.

5.0 Error Codes

Table 5.1 Error Codes

DISPLAY	DESCRIPTION
FA 1	Program Stack Overflow
FA 2	Watchdog Re-start (Processor Crash)
FA 3	Memory Error at start-up (User programming is erased, factory program defaults are re-loaded)
FA 6	Strapping Table range error (measured value lower or higher than the limits of the data table)
FA 7	Strapping Table data entry error (volume values must correspond to the height values in ASCENDING ORDER, data points are out of sequence)
TAb d	Non-Linear Table duplicate data point entered
TAb E	Non-Linear Table emptied
TAb F	Non-Linear Table full (100 data point pairs max.)
Flashing 9's	Display over-range (Decrease number of decimal places shown)

6.0 Specifications

(All values are typical, unless otherwise specified)

ENCLOSURE:	RECTANGULAR PANEL MOUNTED METER
MATERIAL	PLASTIC
SIZE	89mm W X 41.3mm H X 178mm D
BEZEL	112mm W X 62mm h X 17.5mm D
MOUNTING	INTEGRAL SNAP-IN TABS
POWER INPUT:	
CONNECTOR	SCREW TERMINALS L1, L2, GND
VOLTAGE	115 VAC +/- 10%
OPTIONAL	230 VAC +/- 10%
FREQUENCY	47 TO 63 Hz
POWER CONSUMPTION	8 VA MAX
FUSE	INTERNAL (1/4 AMP)
ISOLATION	TRANSFORMER (1000 VAC)
TEMPERATURE RANGE	
OPERATING	0 TO 55 DEG. C
DISPLAY	5 DIGIT, 7 SEGMENT LED WITH SIGN
	0.56 INCH HEIGHT
	FOUR STATUS INDICATOR LED'S
VIEWING DISTANCE	23 FEET
UPDATE RATE	10 TIMES PER SECOND
DISPLAY RANGE	0.0000 TO 99999.
	SCALABLE TO OTHER UNITS
ACCURACY (25 DEG. C)	+/- 0.02% OF FULL SCALE MAXIMUM
RESOLUTION	+/-0.001% OF FULL SCALE
TEMPERATURE DRIFT	+/- 0.01% PER DEG. C
ELECTRICAL INPUTS	
SIGNAL INPUT	4 TO 20 MILLIAMPS
PROGRAM DISABLE	CONNECT TERMINAL #3 TO #4
ELECTRICAL OUTOUTS	
OPTIONAL HI/LO RELAYS	2 ea. FORM 1A N.O.
	3A @ 250 VAC (RESISTIVE)
	1/10 HP @250VAC
	3A @30 VDC (RESISTIVE)
TOTAL ISOLATION	1000 VAC
ANALOG OUTPUT	
RESOLUTION	12 BITS (+/- 0.025%)
NON-LINEARITY	+/-0.1% OF FULL SCALE

7.0 Repair

If the unit displays a Failure Code (“FA XX”), refer to section 5.0 for explanation and recommendations. Contact the factory with complete information on the type of failure codes being displayed. If the unit displays random display values, check the wiring connections. If the unit does not function (no display and no electrical output), check the fuse as follows:

1. Power down the unit.
2. Squeeze the tabs on the top and bottom of the front bezel, and pull the unit from the case. This may take some force – pull firmly on the front panel until it pops out of the case.
3. The fuse is located at the rear of the bottom PC board, next to the power transformer. It is clear plastic, and looks like a small light bulb. Remove the fuse from its socket by lifting it straight up with small nose pliers.
4. Insert the replacement fuse into the socket, and slide the unit back into the case until it snaps into position.

The approved replacement fuses are:

Littlefuse part number: 273-250

Schurter part number: 2030.0014

(Replacement fuses are available from the factory at a modest cost.)

Obtain a proper **Return Materials Authorization** (RMA) number before sending defective units to the factory for repair. To obtain an RMA, call the factory Technical Service Department with the following information :

Serial number of the unit

Model number of the unit

Description of the failure

Return shipping address

Purchase order for all non-warranty repairs

Upon receipt of this information, an RMA can be issued. This number must be written on the outside of the package and the units sent to:

Intelligent Controls, Inc. (INCON)

34 Spring Hill Road

Saco, ME. 04072

No items will be received at the factory without a proper RMA.



Model 1810

Installation & Programming Manual
